

INSTRUCTIONS

Series 1536

DIFFERENTIAL PRESSURE INSTRUMENTS

Diaphragm Sensor

Orange Research

140 Cascade Boulevard, Milford, Connecticut 06460
203 877-5657 800 989-5657 Fax: 203 783-9546
www.orangeresearch.com

Your new Orange Research Differential Pressure Instrument is a rugged instrument featuring simplicity of design to provide dependable and efficient service. Because it is an instrument it should be handled with care. Read all instructions carefully before attempting to install the instrument.

CAUTION: Do not exceed maximum operating pressure listed on instrument label. Use only fluids compatible with wetted parts.

HOW IT WORKS

The instrument operates on the difference between two pressures (delta-P). The sensing element is a spring biased diaphragm which moves linearly in proportion to the difference between two basic pressures. A magnet on the HI pressure side of the diaphragm/magnet assembly moves with the diaphragm and rotates a follower magnet located adjacent to the pressure cavity. The gauge pointer is located at the end of the rotary magnet shaft and rotates with the magnet to provide gauge readings proportional to differential pressure variations. This is accomplished by coupling the forces between two adjacent magnets through a solid wall.

Note: This instrument will provide $\pm 2\%$ accuracy full scale.

INSTALLATION

This gauge is a 1516 with a porting manifold mounted to the back. The mounting holes on the back/bottom and the process ports mimic those found on the Barton 227C gauge. In fact the relative position of the mounting holes and the process ports is exactly the same as the Barton gauge, allowing you to remove the Barton gauge and install this unit in minutes without changing the position of the mounting screws and piping.

If you have a Barton mounting bracket, you can reuse it on our gauge.

The gauge can be mounted to a bracket using the mounting holes on the back of the pressure body, or panel mounted using the three holes on the dial case front flange.

Most differential pressure gauges have two pressure ports, one for high pressure and one for a low pressure connection. Model 1536 has four ¼ inch FNPT ports. Two are high pressure ports and two are low pressure ports. The ports are marked **HI** for high and **LO** for low.

HI-Left ports – standard

The standard configuration, called Hi-Left, has the two high pressure ports on the left and two low pressure ports on the right, as you read the dial

Hi-Right ports – no charge option

An optional Hi-Right configuration has the high pressure ports on the right and the low pressure ports on the left, as you read the dial.

High Pressure on wrong side?

If you have received a gauge with the porting reversed for your setup, another porting manifold with opposite porting can be sent to you. You can easily retrofit the new porting manifold in the field. Please contact Orange Research to have this sent to you.

To retrofit your unit with another porting manifold, remove the four bolts on the back of the unit holding the manifold. (Do not remove the four bolts on the side of the unit!) Remove the two O-rings and assemble the new porting manifold using the same four bolts and the new O-rings. Be sure to lightly grease the new O-rings so they slide into position properly.

The Hi-Left porting manifold on the back is scribed with an "A" on the top, while the Hi-Right porting manifold is scribed with a "B". Please refer to the necessary porting manifold as Hi-Right, Hi-Left or as "A" or "B" so we can be sure to send you the proper manifold. Please also identify the type of O-ring material used on your unit, since we will need to send two more new O-rings, and they will have to match what you have now.

Only two of the four ports are required to measure differential pressure. The additional high and low ports can be used for bleed ports, to connect a pressure gauge or other instrument, or simply to connect additional piping.

Two port plugs are supplied with each unit. Install them in any ports not being used in your installation. Teflon tape should be used on all port connections. Two or three wraps of Teflon tape are recommended.

If you have selected the ½ inch NPT ports option, you will have received four ¼ inch to ½ inch adapters. Install them in as many ports as required with Teflon tape.

- For a Brass body the adapters are Brass
- For an Aluminum body the adapters are SS

Filters

For filter applications, the high pressure port would be piped to the inlet of the filter and the low pressure port would be piped to the outlet of the filter.

Cryogenic Tanks

In the case of a cryogenic tank the high pressure port would be mated to the bottom of the tank while the low pressure port would be mated to the top of the tank, called the vapor space or the ullage.

DP Flow

For dp flow measurement, the high pressure port would be installed on the inlet of the primary flow element while the low pressure port would be installed on the outlet of the flow element.

Installation Notes:

- If there is particulate in the line, insert a screen (approx. 100 micron) to block the particulate from becoming lodged in the instrument
- Do not install on systems for highly viscous fluids or where fluid may become hardened over time
- Do not install on system with iron in the fluid...the iron can become attached to the magnetic sensor
- Install the unit above the process line to prevent particulate settling in the instrument
- We recommend isolating the instrument from the system pressure using valves...3 or 5 way manifold valves are common
- Open valves connected to our instrument slowly, to protect the diaphragm sensor from damage
- Before installation, refer to our Specification Sheets (on our website) to identify instrument component materials & double check for chemical compatibility

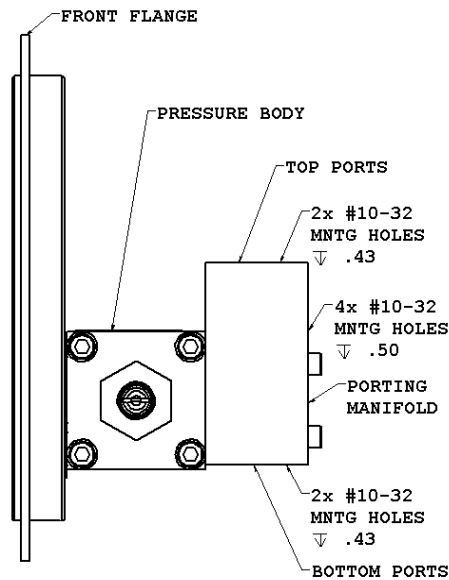

**1536 shown –
See model 1516 for sensor details**

MAINTENANCE

Other than replacing a broken lens there is only one area where this instrument may need attention. Erratic pointer movement may indicate that cleaning is required.

Lens Replacement:

1. Insert pressure body into vise, protecting the body from damage, with the dial facing upwards.
2. Remove the threaded ring using a small screwdriver to loosen ring and remove by hand.
3. Remove lens and gasket.
4. Remove gauge from vise and turn upside down to remove any debris that may be present.
5. Reinstall in vise and reassemble with new lens, making sure the gasket is located under the lens.

Pointer Replacement:

1. Remove lens and gasket, using above instructions with pressure body in vise and gauge pointed upwards.
2. Note exact position of pointer with small pencil mark.
3. Remove old pointer with pointer puller or screwdriver, taking care not to bend the pointer or the pointer pin as they are sensitive components.
4. Install new pointer by hand, to line up with the pencil mark.
5. Rap the center of the pointer hub sharply, to set the pointer into the pin.
6. Erase small pencil mark and remove any debris.
7. Reinstall lens, gasket and bezel.